

225/50 -10 ZKC

Tread Design Modification

Groove - hand Cut proposal

Model 1

Tallado longitudinal para incrementar canal de **5mm a 9mm**.

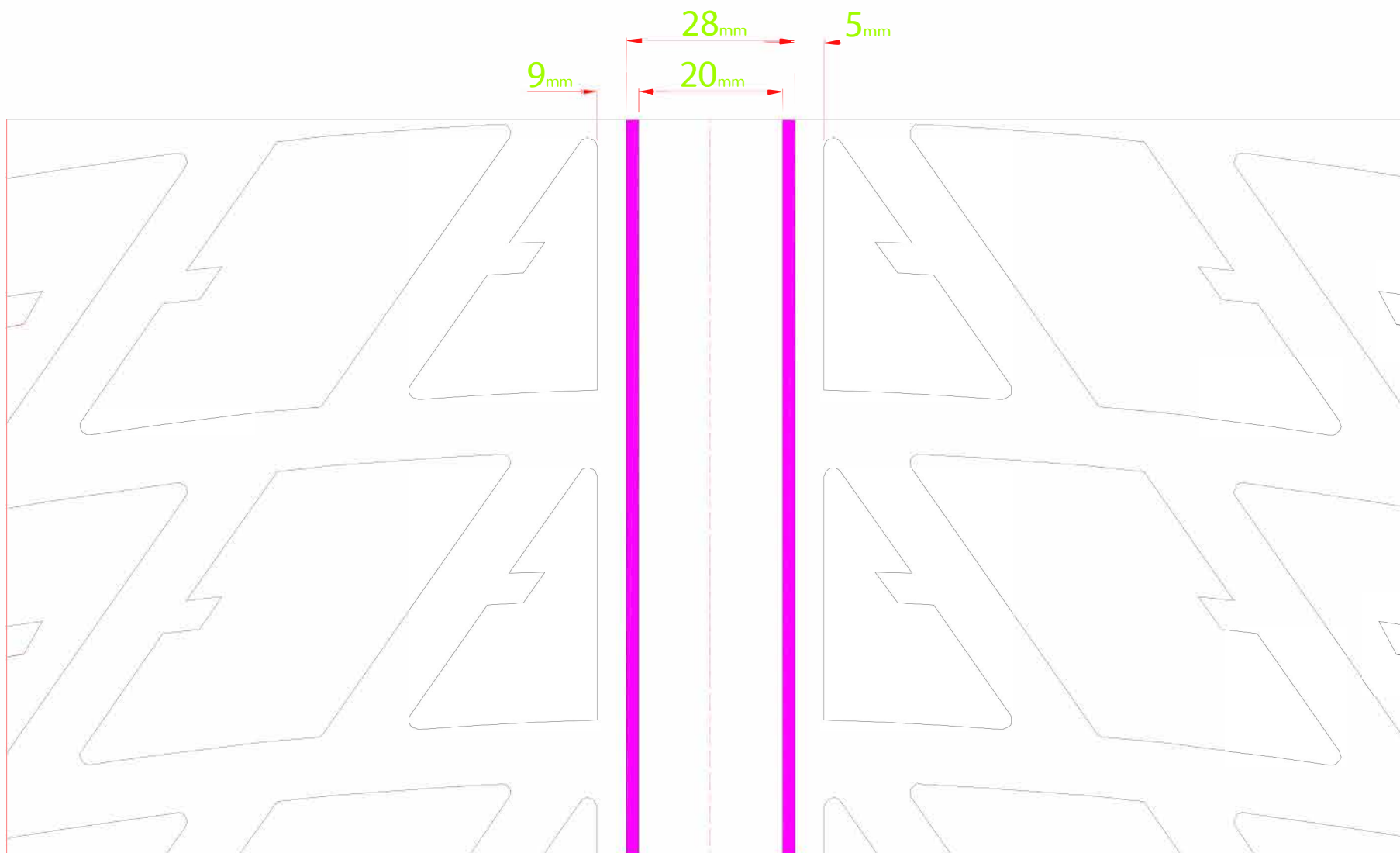

Model 2

Tallado en cinturón, 3mm ancho, 1/2 profundidad. 26 Tallas.

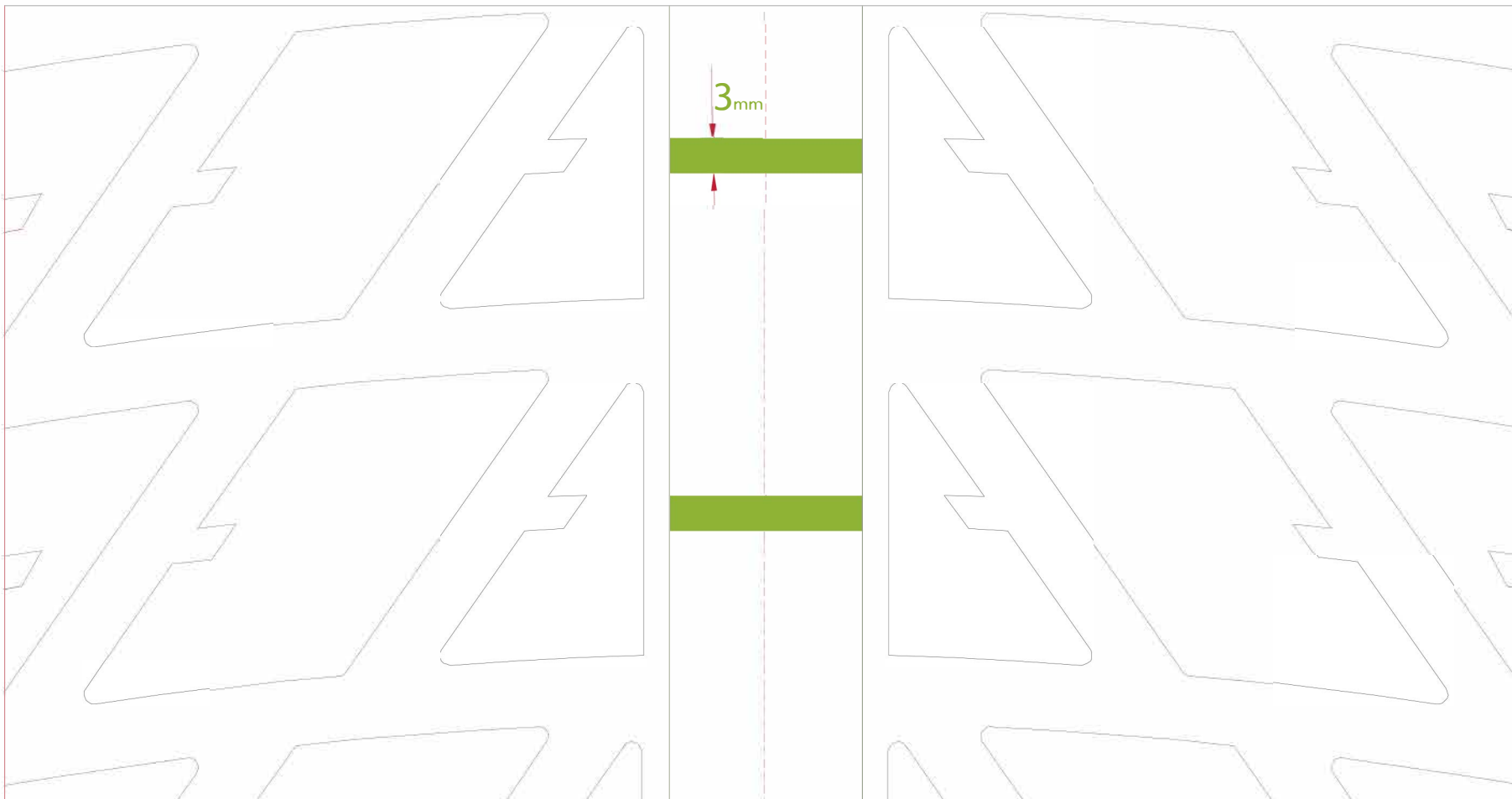

Model 3

Tallado combinado.

